

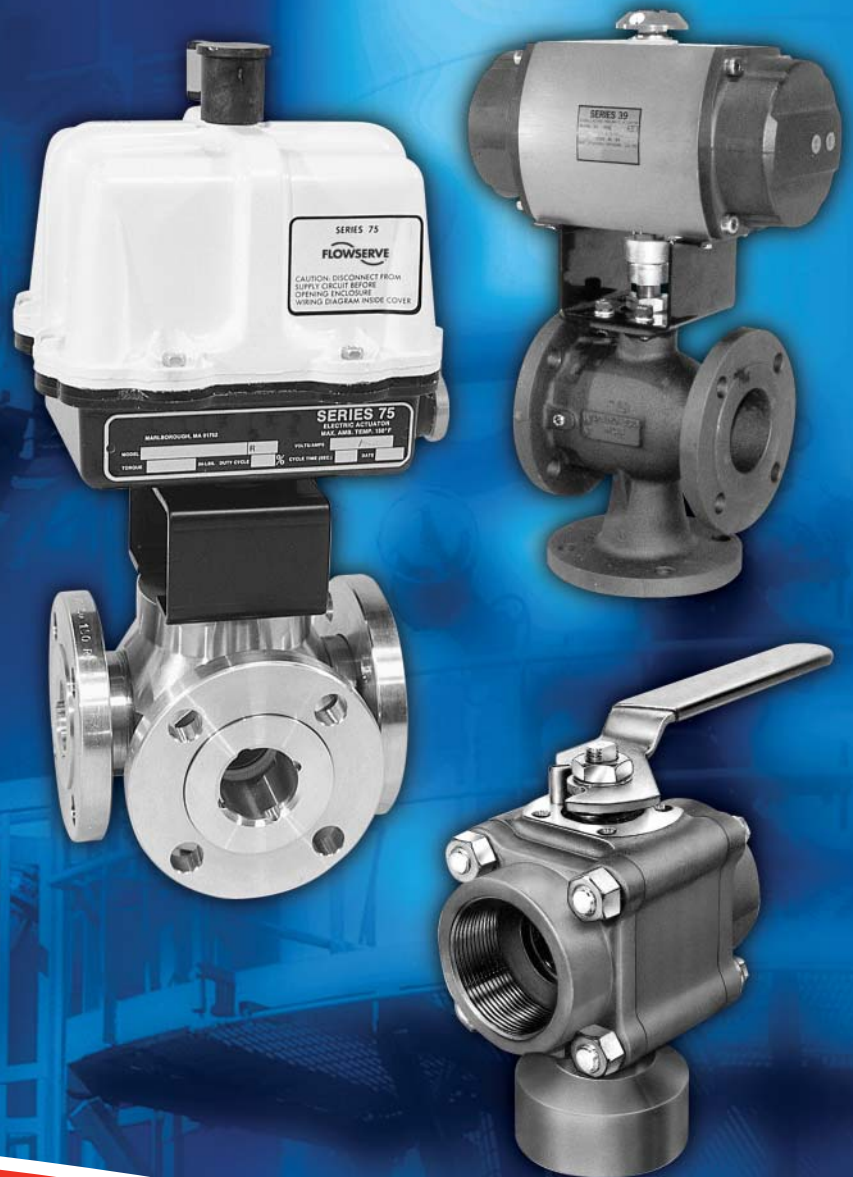

Worcester Controls Directional Ball Valves

Series D44/D4, Series D51, Series 18/19



Experience In Motion



Page 2 Series D44/D4, ½"-2" Bottom Entry

Page 6 Series D51, 2"-8" Bottom Entry

Page 9 Series 18/19, 1"-6" Side Entry

Series D44/D4: A rugged directional ball valve that conforms to the requirements of ANSI B16.34

Diverter Ball Valve

Separate Seats and Body Seals, One Flow Direction

The diverter valve is designed to accept media through a bottom inlet port and direct it out either of two outlet ports. It is commonly used for alternately diverting flow from a single source to two different lines, for example dumping operations in which one outlet permits media to flow from a common source to the process while the other outlet alternately dumps or recirculates excess media.

The Diverter Ball Valve is available with two different porting configurations. V1 Porting is 90° operation for manual,

pneumatic or reversing type electric actuation. The flow from the bottom inlet port cannot be shut off, only diverted to either of the two outlet ports.

V2 Porting is 180° operation for manual or 180° electric actuation. With this configuration, the flow can be shut off by simply operating the valve 90°. However, there is no mechanical stop arrangement for this position.

The diverter valve is constructed with separate seat and body seal.



V1 Porting

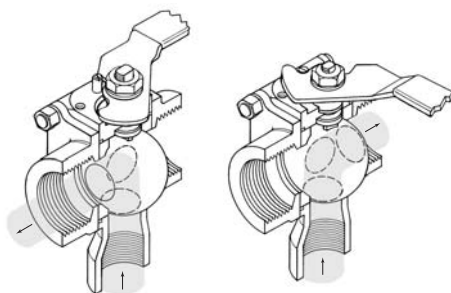

0°

90°

V2 Porting

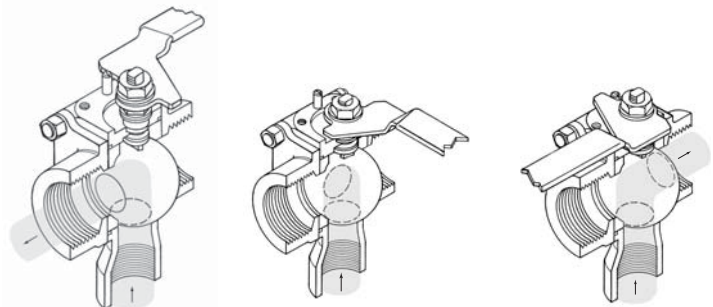

0°

90°

180°

Automation

Diverter and 3-way valves with V1 Porting (90° operations) may be automated with Series 34 or 39 pneumatic actuators or Series 75 electric actuators. For V2 Porting configuration (180° operation), use the Series 75 electric actuator, also available with center-off option. The Series 36 electric actuator is not suitable for use with Worcester Controls Directional Ball Valves. 180° pneumatic actuators are available through custom products.



3-Way Ball Valve

One Piece Seat and Body Seal, Bi-Directional Flow

The 3-way ball valve provides greater flexibility in operation. Constructed with a one piece seat and body seal, the 3-way valve permits flow in both directions. It can function as a selector valve, alternately accepting media from either of two inlet sources and directing through a single outlet. Or, it may be used as a true 3-way valve, accepting media from two inlet sources for alternate discharge through either of two outlet ports. For example, in a pressurized line or system, the inlet port pressurizes or fills the system. The valve is

then operated through its travel to allow the pressurized contents to be discharged through the second outlet port with the original outlet port now functioning as the inlet.

The 3-way ball valve is available with two different porting configurations. V1 Porting provides 90° operation for manual, pneumatic or reversing type electric actuation. With V1 Porting, alternate side ports are shut off at the 0° and 90° positions. V2 Porting shuts off one side at 0°, the opposite side at 180° and both sides at 90°, but there is no mechanical stop at 90°. V2 Porting permits 0° and 180° operation for manual or electric actuation only. Both positions can be shut off completely.

V1 Porting

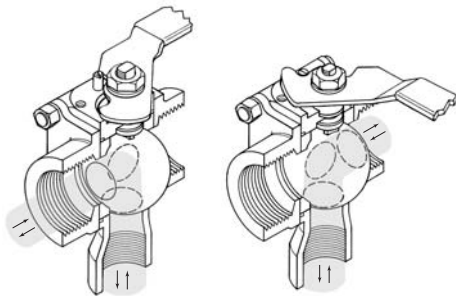

0°

90°

V2 Porting

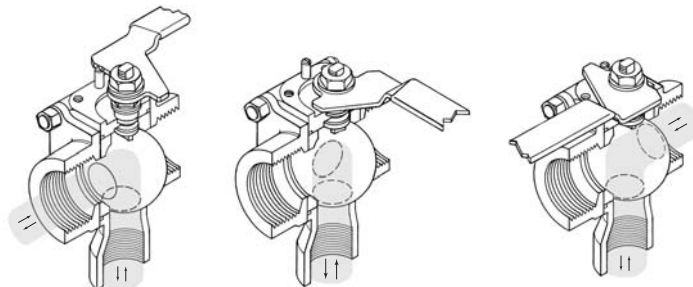

0°

90°

180°

Series D44/D4

**Seat Pressure/Temperature Ratings:
Three-way Ball Valve**

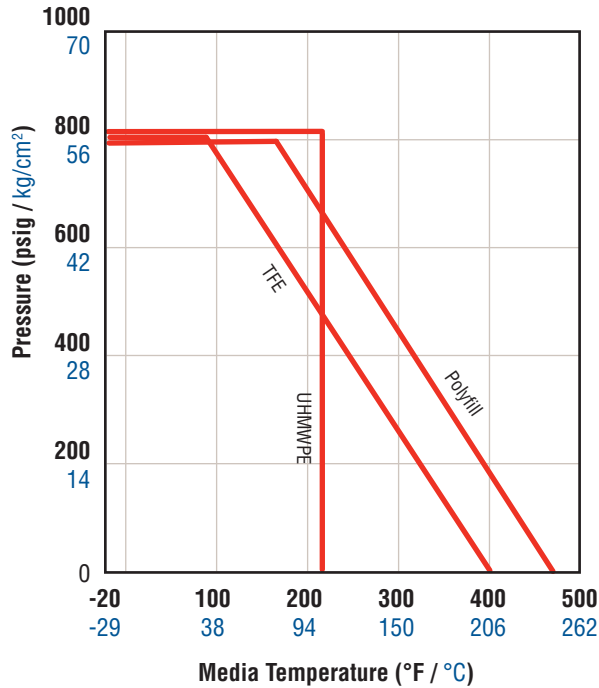

**Seat Pressure/Temperature Ratings:
Diverter Ball Valve**

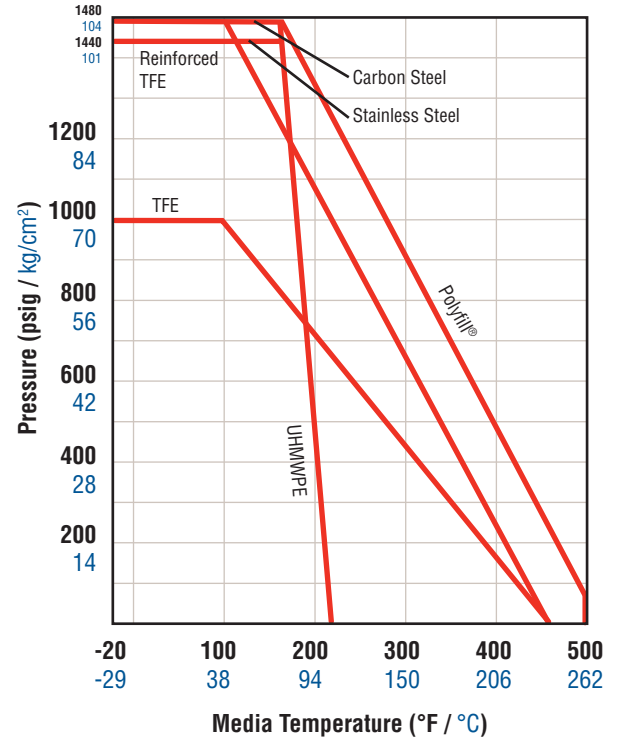

Flow Characteristic Curves for Diverter Valve: V1 Porting, 90° Operation

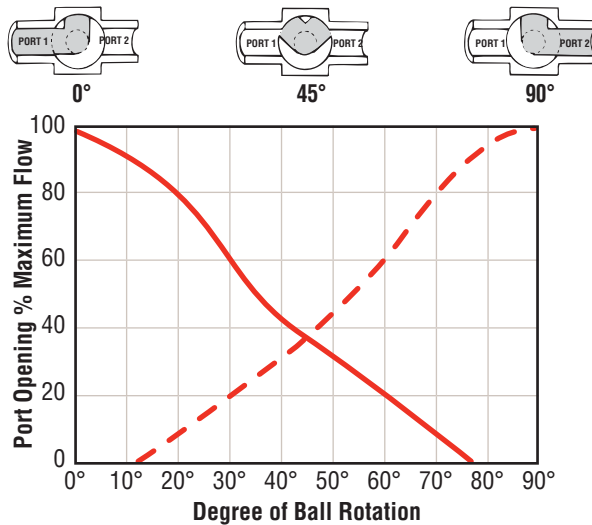

NOTE: In three-way ball valves (one piece seat and body seal), 200°F maximum thermal cycle is allowed for Polyfill seats; 100°F maximum thermal cycle for TFE and UHMWPE seats.

Series D44/D4

Dimensions

Metric dimensions are converted from Standard English dimensions. Dimensions are given for layout purposes only; for tolerances, consult factory.

Flanged versions of the diverter valve are available in 2"–8" in carbon steel or stainless steel with ANSI Class 150 flanges. ANSI Class 300 flanges are also available. Consult factory. Refer to Brochure WCABR1020.

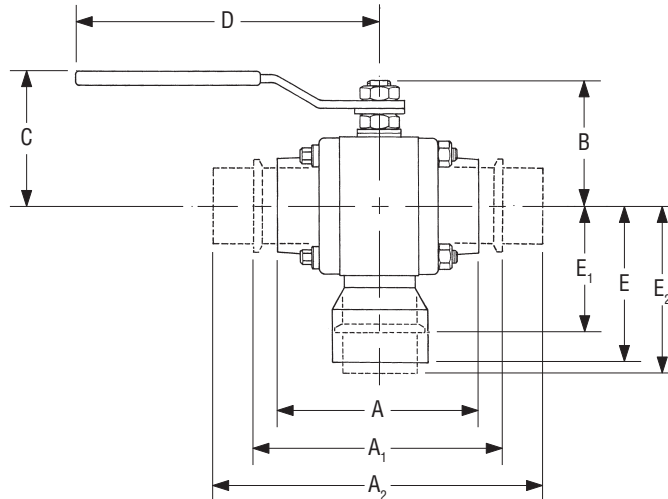

inches / millimeters

Valve	A, SE, SW, TE	A1 TC	A2 XBO	B	C	D	E	E1 TC	E2 XBO	Side Port Dia.	Bottom Port Dia.	Approx. Wt. lb. / kg
½"	2.54	3.50	5.53	1.55	1.76	5.53	2.25	1.66	2.94	.38	.34	1.5
	64.5	88.9	140	39.4	44.7	141	57.2	42.2	74.4	9.7	8.6	0.7
¾"	2.76	4.00	5.77	1.64	1.86	5.53	2.50	1.76	3.03	.52	.50	2.0
	70.1	102	147	41.7	47.2	141	63.5	44.8	76.9	13.2	12.7	0.9
1"	3.66	4.50	6.33	2.19	2.28	6.53	3.06	1.94	3.21	.75	.71	3.6
	93.0	114	161	55.6	57.9	166	77.7	49.3	81.5	19.1	18.0	1.6
1½"	4.50	5.50	7.43	2.88	2.83	8.03	3.56	2.29	3.56	1.25	1.12	7.4
	114	140	189	73.2	71.9	204	90.4	58.2	90.4	31.8	28.4	3.4
2"	4.94	6.25	7.60	3.06	3.02	8.03	3.94	2.44	3.72	1.50	1.38	11.1
	126	159	193	77.7	76.7	204	100	62.0	94.5	38.1	35.0	5.0

Valve Body Pressure Ratings

Carbon Steel and S.S.	ANSI Class 600
½"–1" Brass	1500 psi
1½"–2" Brass	1000 psi

NOTE: These are body pressure ratings. Seat and seal selection will derate the valve.

Flow Coefficient

Valve Size	C _v	Equivalent Length of Schedule 40 Pipe (feet)
½"	3	23.1
¾"	5	36.6
1"	10	33.4
1½"	24	55.6
2"	36	90.1

Optional High Pressure Valves

½"–2"	Series D4 Diverter Valves with Lubetal® (Delrin®) seats are available for high pressure service.	
½"–¾"	Carbon Steel and S.S.	3000 psi
1"	Carbon Steel and S.S.	2500 psi
1½" and 2"	Carbon Steel and S.S.	2000 psi

Series D51: A Simple, Dependable Way to Divert Flow to Two Pipe Lines with Tight Shutoff to Either Line

Worcester's Series D51 is a standardized line of flanged diverter ball valves in sizes 2", 3", 4", 6", and 8" with ANSI Class 150 flanges.

D51 diverter valves are designed to accept media through a bottom inlet port and direct it out either of two outlet ports. They are commonly used for alternately diverting flow from a single source to two different lines; for example, dumping operations in which one outlet permits media to flow from a common source to the process while the other outlet alternately dumps or recirculates excess media.



Ball porting for D51 diverter valves is referred to as V1 (see illustration opposite) for 90° valve operation. Flow from the bottom inlet port cannot be shut off, only diverted to either of the two outlet ports. At either end of the valve stroke,

one port is wide open and the other is shut off bubble-tight. Relief slots assist in sealing and reduce torque. The ball is forced into the seat of the blocked port under pressure to affect and maintain a tight seal.

Series D51 Options

V2 porting for 180° full shutoff operations and T51 three-way valves for bidirectional flow applications are available through Custom Products.

Automation

D51 flanged diverter valves may be automated with Series 75 electric actuators (refer to brochure WCABR1014) or Series 39 double piston pneumatic actuators (refer to brochure WCABR1003). Both actuators may be used in on/off or modulating applications. Limit switches, feedback potentiometers, 4-20 mA circuit boards providing remote indication of valve position and other accessories including a full line of advanced positioners are available.

Flow Coefficient

Valve Size	C _v	Equivalent Length of Schedule 40 Pipe (feet)
2"	36	95
3"	135	62.5
4"	230	81
6"	330	312
8"	605	387

Seat Pressure/Temperature Rating

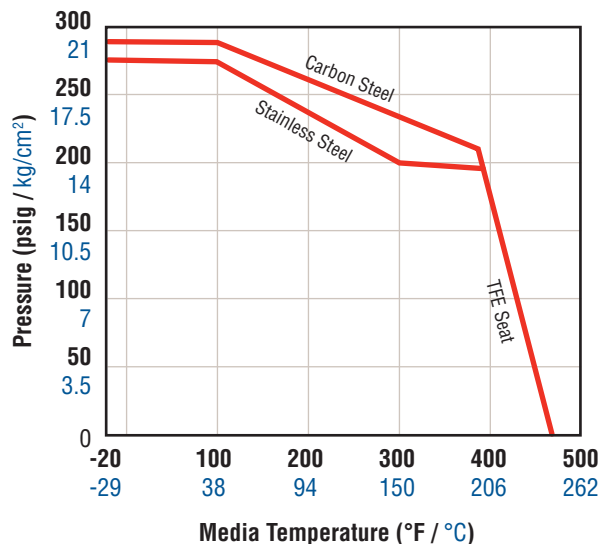

Flow Characteristic Curves for Diverter Valve V1 Porting, 90° Operation

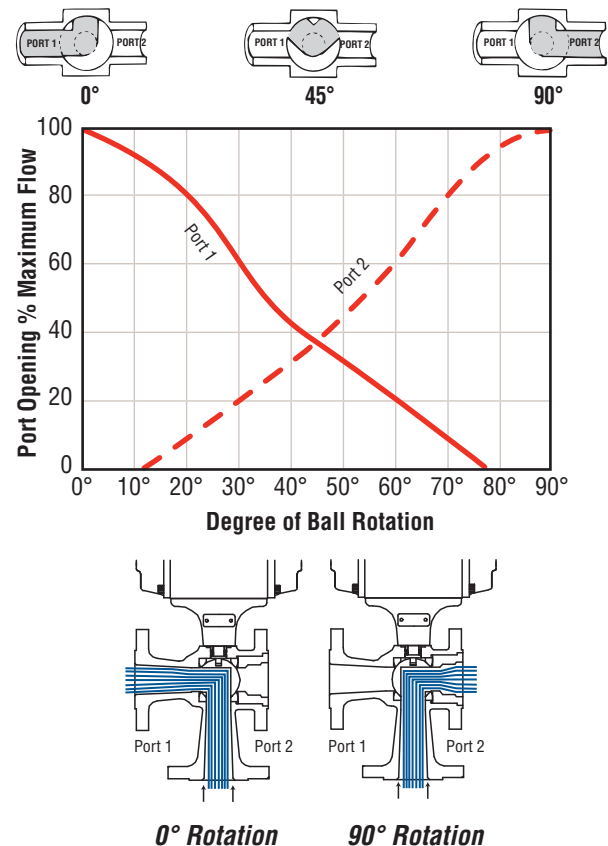

Parts Identification and Materials Specifications

Series D51

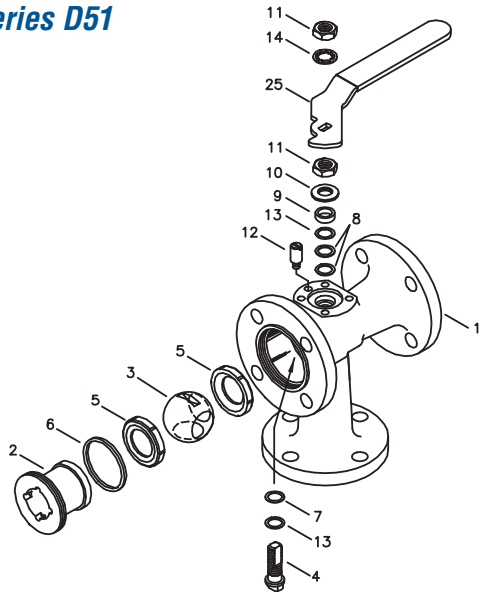

2" D51

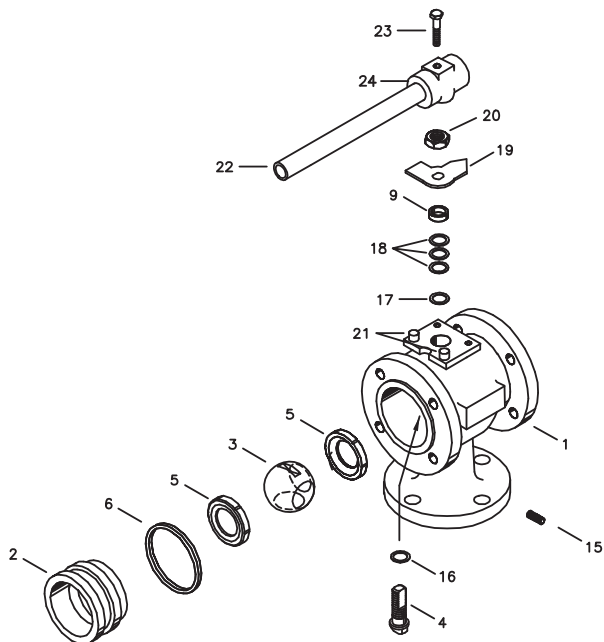

3", 4", 6", 8" D51

Part	Part Name	Qty.	Materials
1	Body	1	Carbon Steel - ASTM 216 – WCB Stainless Steel - ASTM A351 CF8M
2	End Plug	1	Carbon Steel - ASTM A108 Stainless Steel - ASTM A479 - 316, Cond. A
3	Ball	1	Stainless Steel - ASTM A479 - 316, Cond. A
4	Stem	1	Stainless Steel - ASTM A479 - 316, Cond. A
5	Seats	2	TFE
6	Body Seal	1	TFE
7	Thrust Bearing	1	Polyfill®
8	Stem Seal	2	Polyfill®
9	Follower	1	Stainless Steel - ANSI 316L
10*	Belleville Washers	2	Carbon Steel - Zinc Plated Stainless Steel 301
11*	Handle & Ret. Nuts	2	Carbon Steel - Zinc Plated Stainless Steel - ANSI 300 Series
12	Stop Screw	1	Carbon Steel - Black Oxide Coated
13	Thrust Bearing/ Seal Protector	2	PEEK
14	Lockwasher	1	Carbon Steel - Zinc Plated Stainless Steel - ANSI 300 Series
15	Shipping Screw	4-12	Stainless Steel - ANSI 304
16	Thrust Bearing	1	RTFE - Reinforced
17	Centering Washer	1	Carbon Steel - Black Oxide Coated Stainless Steel - ANSI 316
18	Stem Seals	3	RTFE - Reinforced
19	Stop Plate	1	Carbon Steel - Zinc Plated
20	Retaining Nut	1	Carbon Steel - Zinc Plated Stainless Steel - ANSI 300 Series
21	Stop Screw	2	Carbon Steel - Black Oxide Coated
22	Wrench Extension	1	Carbon Steel - ASTM A53/Galv.
23	Wrench Assy. Bolt.	1	Carbon Steel - SAE J429 GR.2
24	Wrench Block	1	Malleable Iron - ASTM A47, Black Oxide Coated
25	Handle	1	Carbon Steel - Zinc Plated, Vinyl Coated Stainless Steel - ANSI 300 Series, Vinyl coated

* **NOTE:** Four Belleville washers, and a lock nut (in place of handle and retaining nuts) are used if the valve is automated with a pneumatic or electric actuator.

Series D51

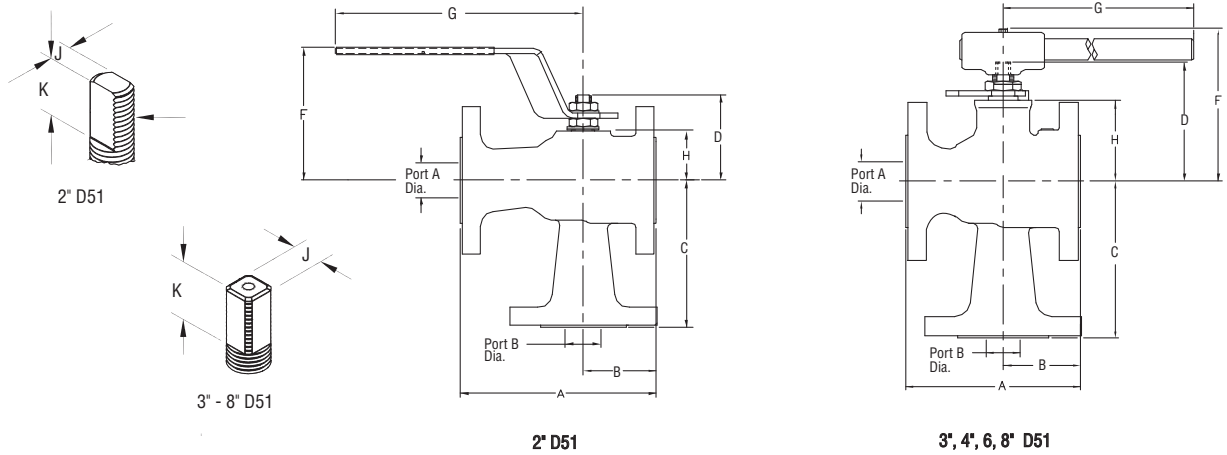

Dimensions

inches / millimeters

Valve Size	Ball Port A Dia.	Ball Port B Dia.	A	B	C	D	F	G	H	J	K	Weight lb. / kg
2"	1.44	1.44	7.00	2.68	5.00	3.06	4.77	8.10	1.92	.343	.60	26.5
	36.6	36.6	178.0	68.1	127.0	77.8	121.2	205.7	48.8	8.71	15.24	12.0
3"	2.50	2.00	8.00	3.63	6.00	5.69	7.22	22.00	3.88	.745	.65	52.6
	63.5	50.8	203.2	92.2	152.4	144.5	183.4	559.0	98.6	18.92	16.51	23.6
4"	3.25	2.50	9.00	4.00	7.13	6.31	7.84	22.00	4.48	.745	.65	80.7
	82.6	63.5	228.6	101.6	181.1	160.3	199.1	559.0	113.8	18.92	16.51	36.6
6"	3.94	3.00	10.50	4.25	9.85	8.96	11.21	26.00	6.19	1.12	1.03	137.8
	100.1	76.2	266.7	108.0	250.2	227.6	284.7	660.0	157.2	28.45	26.16	62.5
8"	5.69	4.00	11.50	5.69	11.00	10.08	12.31	26.00	7.28	1.12	1.03	204.0
	144.5	101.6	292.0	144.5	279.4	256.0	312.7	660.0	184.9	28.45	26.16	92.5

Series 18/19: Upgrade the efficiency of your fluid diverting, filling and distribution systems through piping simplification, automation and safety



Flowserve Worcester Controls' Series 18 and 19 multi-way valves are designed to improve the efficiency and productivity of your process systems with up to 5 ports, slip-on flanges, multiple seat and body materials, standard or full port, and optional pneumatic and electric automation and anti-fugitive emission design. Screwed, socket weld and butt weld ends are available as are slip-on flanges (ANSI Class 150 or 300).

Worcester Controls' multi-way valves are available in four general configurations:

- Series 18 side entry, standard port valves
- Series B18 side entry, full port valves
- Series 19 bottom and side entry, standard port valves
- Series B19 bottom and side entry, full port valves

The wide variety of ball ports and piping connections present a large number of diverting possibilities.

Series 18 and 19 multi-way valves are available in sizes 1", 1½", 2", 3", 4" and 6". Standard body materials are carbon steel and type 316 stainless steel; standard seat/seal materials are TFE and Polyfill®.

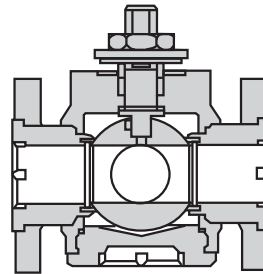

Series B18 Full Port Side Entry Valve

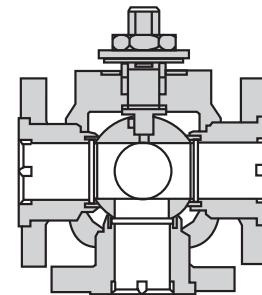

Series B19 Full Port Bottom Entry Valve

Flow Coefficient

Valve Size (Inches)	C _v		Operating Torque (in-lb)	
	Std. Port 90° Flow	Full Port 90° Flow	Standard Port	Full Port
1	9	19	95	220
1½	46	46	220	305
2	49	85	305	800
3	149	204	1600	2500
4	210	360	2500	4800
6	505	880	4700	11000

Seat Pressure/Temperature Ratings

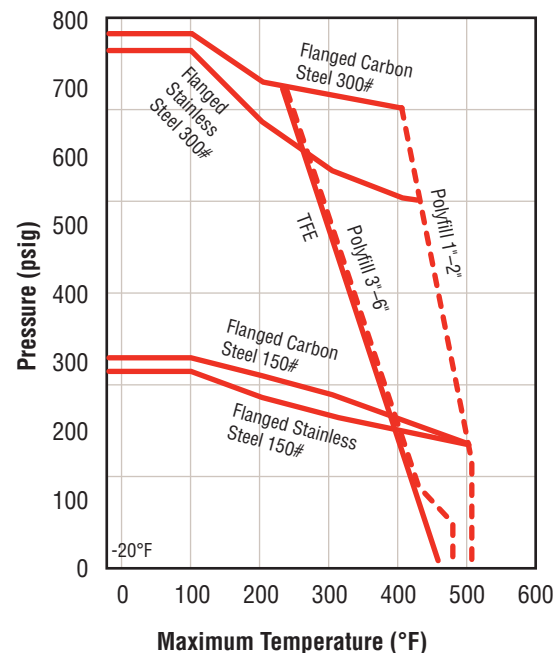

Optional Screwed, Socket Weld and Butt Weld End



Pneumatic Automation



Electric Automation



Anti-Fugitive Emission Valve Option (Series E18 or E19)

Series 18/19

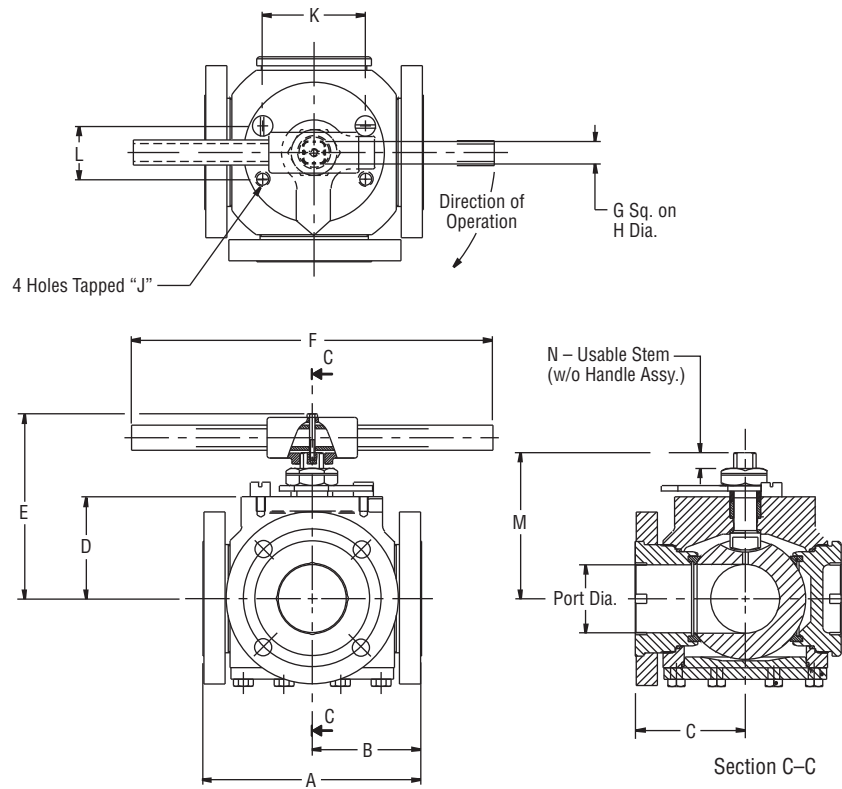

Dimensions: Series 18 Side Entry Standard Port Ball Valves

inches / millimeters

Valve size	A		B		C		D	E	F	G	H	J	K	L	Port Dia.	M	N
	ANSI Class 150	ANSI Class 300	ANSI Class 150	ANSI Class 300	ANSI Class 150	ANSI Class 300											
1"	5.00	6.50	2.50	3.25	3.05	3.25	1.35	3.51	7.28	0.297	0.44	1/4-20	1.17	1.17	0.67	2.25	.42
	127	165	63.5	82.6	77.5	82.6	34.3	89.2	185	7.5	11.2		29.7	29.7	17.0	57.2	10.7
1 1/2"	6.50	7.50	3.25	3.75	3.25	4.13	2.72	5.97	10.00	0.551	0.79	M8	2.75	1.25	1.46	4.36	.73
	165	191	82.6	95.3	82.6	105	69.1	152	254	14.0	20.1		69.9	31.8	37.1	111	18.5
2"	7.00	8.50	3.50	4.25	3.94	4.25	2.72	5.97	10.00	0.551	0.79	M8	2.75	1.25	1.46	4.36	.73
	178	216	88.9	108.0	100	108	69.1	152	254	14.0	20.1		69.9	31.8	37.1	111	18.5
3"	9.50	11.14	4.75	5.57	4.75	5.57	4.05	7.48	24.00	0.745	0.88	M10	3.38	1.75	2.52	5.95	.65
	241	283	121	142	121	142	103	190	610	18.9	22.4		85.9	44.5	64.0	151	16.5
4"	12.00	12.00	6.00	6.00	6.00	6.89	4.44	7.87	24.00	0.745	0.88	M10	3.38	1.75	2.95	6.28	.65
	305	305	152.4	152	152.4	175	113	190	610	18.9	22.4		85.9	44.5	74.9	160	16.5
6"	15.50	15.88	7.75	7.94	7.75	7.94	5.91	10.83	28.50	1.120	1.39	M12	4.00	3.00	3.86	8.58	1.03
	394	403	197	202	197	202	150	275	724	28.4	35.3		102	76.2	98.0	218	26.2

Series 18/19

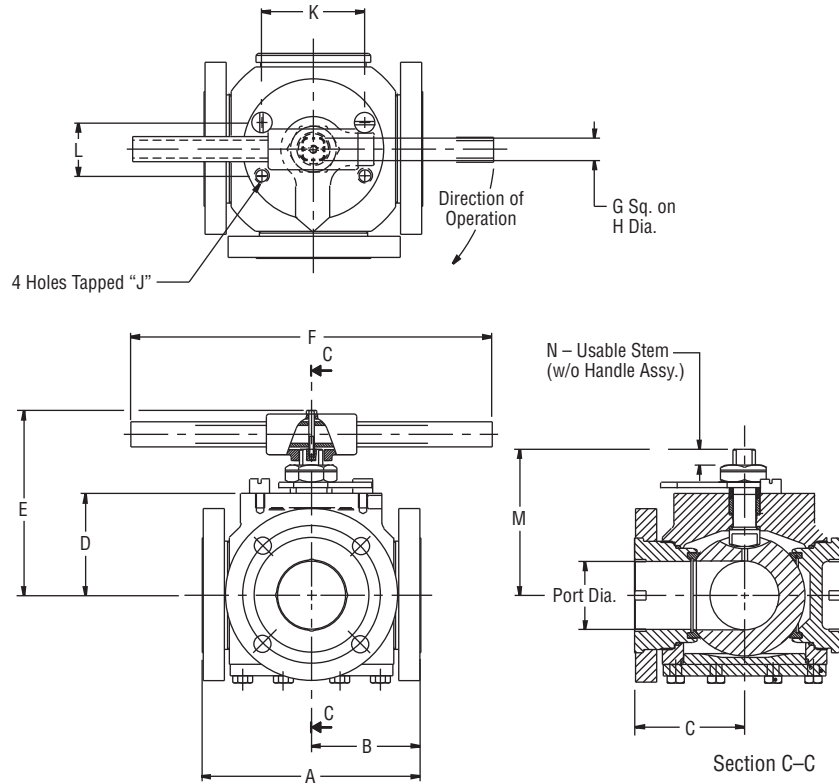

Dimensions: Series B18 Side Entry Standard Port Ball Valves

inches / millimeters

Valve size	A		B		C		D	E	F	G	H	J	K	L	Port Dia.	M	N
	ANSI Class 150	ANSI Class 300	ANSI Class 150	ANSI Class 300	ANSI Class 150	ANSI Class 300											
1"	5.00	6.50	2.50	3.25	2.95	3.25	1.72	4.91	9.53	0.343	0.56	¼-20	1.39	1.39	0.95	2.85	.59
	127	165	63.5	82.6	74.9	82.6	43.7	125	242	8.7	14.2		35.3	35.3	24.1	72.4	15.0
1½"	6.50	7.50	3.25	3.75	3.25	4.13	2.72	5.97	10.00	0.551	0.79	M8	2.75	1.25	1.46	4.36	.73
	165	191	82.6	95.3	82.6	105	69.1	152	254	14.0	20.1		69.9	31.8	37.1	111	18.5
2"	8.00	8.50	4.00	4.25	4.00	4.25	3.08	6.33	10.00	0.551	0.79	M8	2.75	1.25	1.93	5.31	.73
	203	216	102	108	102	108	78.2	161	254	14.0	20.1		69.9	31.8	49.0	135	18.5
3"	9.50	11.14	4.75	5.57	4.75	5.57	4.44	7.87	24.00	0.745	0.88	M10	3.38	1.75	2.95	6.28	.65
	241	283	121	142	121	142	113	190	610	18.9	22.4		85.9	44.5	74.9	160	16.5
4"	12.00	12.00	6.00	6.00	6.00	6.89	5.91	10.83	28.5	1.120	1.39	M12	4.00	3.00	3.86	8.58	1.03
	305	305	152	153	152	175	150	275	724	28.4	35.3		102	76.2	98.0	218	26.2
6"	15.50	15.88	7.75	7.94	7.75	7.94	7.36	12.28	28.50	1.120	1.39	M12	4.00	3.00	5.83	10.03	1.03
	394	403	197	202	197	202	187	312	724	28.4	35.3		102	76.2	148	255	26.2

NOTE: Dimensions for the Series 19 and B19 bottom and side entry ball valves are similar to the Series 18 and B18 with the addition of the bottom flange with dimension C from the centerline. Weights of Series 18/19 valves vary depending upon the number of ports selected. Consult Flowserve.

Series 18/19 Diverting Options (Plan Views)

Three-Way Series 18 and B18 Options 90° — Side Entry

L Port	T Port			
LA1	TA1	TA2	TA3	TA4

Three-Way Series 18 and B18 Options 180° — Side Entry

L Port	T Port			
LB1	TB1	TB2	TB3	TB4

Series 19 and B19 — Bottom Entry

Two-Way Option 90°	Two-Way Option 180°	Three-Way Option 180°	Four-Way Option 360°
L Port		T Port	L Port
LA1	LB1	TB1	LD1

Flowserve Worcester Directional Ball Valves



! **CAUTION:** Ball valves can retain pressurized media in the body cavity when closed. Use care when disassembling. Always open valve to relieve pressure prior to disassembly.

Due to continuous development of our product line, we reserve the right to alter the information contained in this brochure as required.

Worcester is a registered trademark of Flowserve Corporation. Polyfill® is a registered trademark of Flowserve Corporation. Lubetal® is a trademark of Garlock Inc. Delrin® and Viton® are registered trademarks of E.I. DuPont de Nemours and Company.



How to Order

Series D44/D4

1"	D	X	44	6	6	T	M	SW	V1
Size	Type	Special Service Options	Series	Body & Pipe Ends	Ball & Stem	Seats*	Body Seals*	End Types §	Porting
½"	D – Diverter	V – Vacuum Service	44	1 – Brass (¾"–2")	6 – 316 Stainless Steel	T – TFE	T – TFE	SE – Screw End	V1
¾"	T – 3-way	X – Oxygen Service	4**	4 – Carbon Steel		P – Polyfill	B – Buna	SW† – Socket Weld	V2
1"		G – Grounded Stem		6 – 316 Stainless Steel		Y – Lubetal	E – EPR	TE†† – Tube End	
1½"		E – No handle, Valve built for automation				R – Reinforced TFE	M – TFE Coated Gasket	TC – Quick Disconnect	
2"						U – UHMWPE	V – Viton®	XBO – Extended Butt Weld	
						B – Buna	N – Neoprene	NP – No Pipe Ends	
						N – Neoprene	U – UHMWPE		

ORDERING EXAMPLE: 1" Diverter Valve for Oxygen Service, Stainless Steel Body and Pipe Ends with Stainless Steel Ball and Stem, TFE Seats and Seals, Socket Weld Ends, and V1 Porting.

* The body seal is integral with the seat (one piece) on 3-way valves. 3-way valves are available with Fluoropolymer (T), Polyfill (P), or UHMWPE (U) seats only. When ordering 3-way valves, ignore the body seal column. Example: 1"TX4466USEV1.

** Optional high pressure valve with Lubetal seats only.

§ In some cases, other pipe end styles are available for the right and/or left ports. Consult your Worcester Controls Distributor.

† Carbon Steel or Stainless Steel only.

†† Brass only.

NOTE:

- 3-way valves cannot be used in steam service or applications with large thermal cycles.
- 3-way valves do not have a separate body seal.
- Diverter valves with metal body seals as well as filled metal seats are available. Consult Worcester Controls.
- Multiport (diverter) valves are also available. Refer to brochure WCABR1002.
- WK44 with XBO and TC end connections available as Three-Way. Refer to brochure WCABR1035.
- Lubetal Seats cannot be used for oxygen service.

Series D51

3"	D	51	6	6	T	150	V1**
Size	Type	Series	Body & Pipe Ends	Ball & Stem	Seats & Body Seals	End Types	Porting
2"	D - Diverter	51 - Flanged Valve	4 - Carbon Steel	6 - 316 Stainless Steel	T - TFE	150 - ANSI Class 150 Flanges	V1 - Porting 1*
3"			6 - Stainless Steel				
4"							
6"							
8"							

**Variations (V-Numbered Options) are noted at the end of the order number if needed. Leave blank if no variations. See list below for details.

Ordering Example: 3" Series D51 Flanged Diverter Valve with stainless steel body, stainless steel ball and stem, TFE Seats and body seal, ANSI Class 150 Flanges, and V1 Porting.

Note: Series D51 valves use standard Series 51 repair kits. Multiport diverter valves are also available. Refer to brochure WCABR1002.

! **CAUTION:** Series D51 flanged diverter valves with V1 porting (90° operation) lack indication of flow direction. The user should consider providing external flow indication when using these valves. Ball valves can retain pressurized media in the body cavity when closed. Use care when disassembling. Always open valve to relieve pressure prior to disassembly.

Variations (V-numbers): Listing of V-Number Descriptions

V5 - Hydrostatic Testing	V37 - Cert. of Compliance & Hydro Testing
V6 - Source Inspection	V46 - Silicon Free Lubricant
V14 - Handleless Valves	V51 - High Cycle Stem Build
V17 - Grounding Thrust Bearing	V66 - Cert. of Compliance for European valve orders/contracts
V36 - Certificate of Compliance	

How to Order

Series 18/19

2"	B	18	4	6	P	T	150	LA1
Size	Options	Series	Body & Pipe Ends	Ball & Stem	Seats	Body Seals	End Types	Diverting Options
1"	Blank – Standard Port with Handle	18 – Side Entry	4 – Carbon Steel	6 – Stainless Steel	T – TFE	T – TFE	150 – ANSI Class 150 Flanges	LA1
1½"		19 – Bottom and side Entry						LB1
2"	E – Standard Port, no Handle	19 – Bottom and side Entry	6 – Stainless Steel				300 – ANSI Class 300 Flanges	LD1
3"	B – Full Port, with handle							TA1
4"								TA2
6"	BE – Full Port, no handle							TA3
								TA4
								TB1
								TB2
								TB3
								TB4

The above code describes a 2" Series B18 side entry, full port valve (with handle) with carbon steel body and flanges, stainless steel trim, Polyfill seats, TFE body seals and ANSI Class 150 flanges, with LA1 porting.

NOTE: These valves are custom products. Please consult Flowserve for multi-way valve torque and more detailed dimensional information.



United States
Flowserve Corp.
Flowserve Flow Control
1978 Foreman Drive
Cookeville, TN 38501 USA
Telephone: 1 931 432 4021
Telefax: 1 931 432 5518

FCD WCABR1052-01 Printed in USA.

To find your local Flowserve representative:

For more information about Flowserve Corporation, visit
www.flowserve.com or call USA 1 800 225 6989

Flowserve Corporation has established industry leadership in the design and manufacture of its products. When properly selected, this Flowserve product is designed to perform its intended function safely during its useful life. However, the purchaser or user of Flowserve products should be aware that Flowserve products might be used in numerous applications under a wide variety of industrial service conditions. Although Flowserve can (and often does) provide general guidelines, it cannot provide specific data and warnings for all possible applications. The purchaser/user must therefore assume the ultimate responsibility for the proper sizing and selection, installation, operation, and maintenance of Flowserve products. The purchaser/user should read and understand the Installation Operation Maintenance (IOM) instructions included with the product, and train its employees and contractors in the safe use of Flowserve products in connection with the specific application.

While the information and specifications contained in this literature are believed to be accurate, they are supplied for informative purposes only and should not be considered certified or as a guarantee of satisfactory results by reliance thereon. Nothing contained herein is to be construed as a warranty or guarantee, express or implied, regarding any matter with respect to this product. Because Flowserve is continually improving and upgrading its product design, the specifications, dimensions and information contained herein are subject to change without notice. Should any question arise concerning these provisions, the purchaser/user should contact Flowserve Corporation at any one of its worldwide operations or offices.

© 2011 Flowserve Corporation, Irving, Texas, USA. Flowserve is a registered trademark of Flowserve Corporation.