

MAX-AIR RACK & PINION ACTUATORS



MT SERIES PNEUMATIC ROTARY ACTUATORS



FEATURES

COMPACT DESIGN

The MAX-AIR rack & pinion pneumatic actuator produces linear torque output in a compact design utilizing the same body and end caps for double-acting and spring-return units.

NAMUR MOUNTING

Namur VDI/VDE 3845 and ISO 5211 dimensions on all sizes. No special blocks are required to mount solenoid valves, limit switches or positioners.

DEGREE OF TRAVEL

The standard angle of rotation is 90°. Additional travel rotations through 180° are available. For sizes from MT16 through MT66, Max-Air actuators feature dual travel stops that provide $\pm 10^\circ$ stroke rotation on both the opening and closing phases of the actuator stroke. 110° of travel in a standard 90° actuator!

MULTIPLE OUTPUT SHAFTS

The female pinion drive is standard with a double-square output drive, and optional with a double-D drive, keyed drive and designs to meet your specific requirements.

HIGH-CYCLE BEARINGS

Shaft bearings isolate the pinion gear from the housing and support the shaft for high-cycle applications. Many competitive manufacturers do not provide this critical feature.

RUGGED TOOTH DESIGN

The pinion teeth are engaged the full length and stroke of the piston. The pinion height allows manual override without needing to remove the indicator.

HIGH VISIBILITY POSITION INDICATION

External open/close indicator as standard, available for all rotations.

HIGH CYCLE-LIFE WEAR PADS

Pistons incorporate double wear pads (skates) to separate the rack from the actuator wall and serve as both guide and wear bearings.

PRE-LOADED SPRING CARTRIDGES FOR SAFETY

Epoxy-coated special steel springs are pre-loaded with non-metallic materials. The stainless steel end-cap fasteners are extra long to allow for spring relaxation. All parts are corrosion-resistant.

ALTERNATIVE OPERATING MEDIA

Air pressure operation from 2 to 10 Bar (40 to 150 PSI). Water, nitrogen and compatible hydraulic fluids may also be used to power the actuator.

STAINLESS STEEL FASTENERS

All external fasteners are corrosion-resistant stainless steel.

HONED BORE FOR HIGH CYCLE-LIFE

Extruded aluminum body is internally machined and lapped to exact specifications. Honing prevents dry spots from forming within the actuator bore and therefore eliminates premature seal failure—a critical aspect to long cycle-life. All internal and external surfaces are hard anodized for corrosion resistance, with all units permanently lubricated at the factory.

TRACEABILITY

All units are externally stamped with a progressive traceable serial number.

QUALITY ASSURANCE

100% of all units are factory pressure and leak tested, and individually boxed for shipment.

BEST WARRANTY IN THE INDUSTRY

Max-Air products are covered by our unlimited cycle-life warranty. Contact your representative for more details.

ACCESSORIES

Max-Air offers a wide range of adapters for many different types of valves—including butterfly valves, ball valves and plug valves—as well as a variety of pneumatic and electric automation accessories suitable for diverse industrial environments.

Please call for details.



Introducing the NEW MT Series Actuators!

The MT series offers a flangeless design which makes automation easy. MT series actuators also come standard with two ISO bolt circles, which eliminates the need for a removeable mounting flange.

DOUBLE ACTING TORQUE VALUES

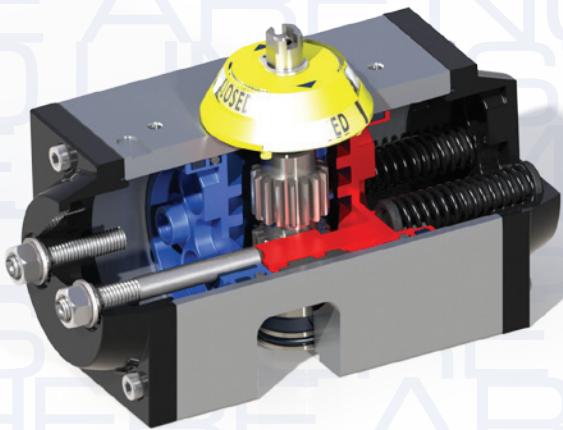

TYPE	40 PSIG	60 PSIG	80 PSIG	100 PSIG	120 PSIG
MT04	40	60	80	100	120
MT12	62	94	125	156	187
MT08	110	147	207	259	295
MT16	137	206	275	344	412
MT17	180	270	360	450	540
MT21	250	375	500	625	750
MT26	375	562	750	937	1125
MT31	500	750	1000	1250	1500
MT36	800	1200	1600	2000	2400
MT41	1000	1500	2000	2500	3000
MT46	1562	2344	3125	3906	4687
MT51	2250	3375	4500	5625	6750
MT56	3000	4500	6000	7500	9000
MT61	4550	6825	9100	11375	13650
MT66	6000	9000	12000	15000	18000
MT71	11750	17625	23500	29375	35250
MT76	15750	23625	31500	39375	47250

OPERATION REFERENCE DIAGRAM

DOUBLE ACTING

CLOSED

OPENING PHASE

OPEN

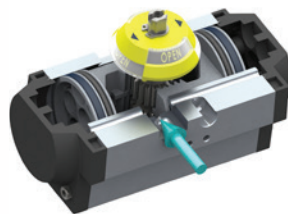
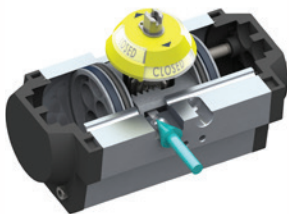

AIR IN #4 = PISTONS CLOSED

OPEN

CLOSING PHASE

CLOSED

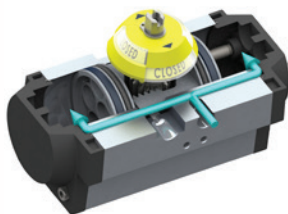
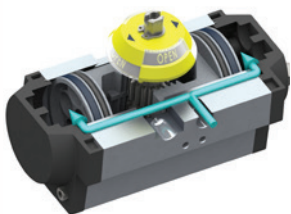

AIR IN #2 = PISTONS OPEN

SPRING RETURN

CLOSED

OPENING PHASE

OPEN

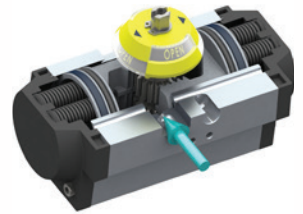

AIR IN #4 = PISTONS OPEN (SPRINGS COMPRESS)

OPEN

CLOSING PHASE

CLOSED

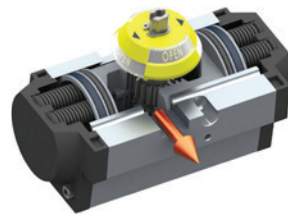

AIR FAILURE = PISTONS CLOSE (SPRINGS RELAX)

SPRING RETURN MT12–MT46

		POS. 1 CLOSING TORQUE (SPRING)		POS. 2–OPENING TORQUE									
				40 PSIG		60 PSIG		80 PSIG		100 PSIG		120 PSIG	
#Springs	START	END	START	END	START	END	START	END	START	END	START	END	
MT12	1+1	33	22	40	29	72	61	103	92	134	123	165	154
	2+2	66	44	–	–	50	28	81	59	112	90	143	121
	3+3	99	66	–	–	–	–	58	27	90	66	121	88
MT08	1+1	33	20	90	78	127	115	187	175	239	227	275	263
	2+2	65	40	70	45	107	82	167	142	219	194	255	230
	3+3	98	60	50	13	87	50	147	110	199	162	235	198
	4+4	130	80	–	–	67	17	127	77	179	129	215	165
	5+5	163	100	–	–	–	–	107	45	159	97	195	133
MT16	2+2	75	53	84	62	153	131	222	200	291	269	359	337
	3+3	112	81	56	25	125	94	194	163	263	232	331	300
	4+4	150	107	–	–	99	56	168	125	237	194	305	262
	5+5	187	134	–	–	72	19	141	88	210	157	278	225
	7+5	224	160	–	–	–	–	115	51	184	120	252	188
MT17	2+2	93	64	116	87	206	177	296	267	386	357	476	447
	3+3	139	96	84	41	174	131	264	221	354	311	444	401
	4+4	185	128	–	–	142	85	232	175	322	265	412	355
	5+5	232	160	–	–	110	38	200	128	290	218	380	308
	7+5	278	192	–	–	–	–	168	82	258	172	348	262
MT21	2+2	122	92	158	128	283	253	408	378	533	503	658	628
	3+3	184	138	112	66	237	191	362	316	487	441	612	566
	4+4	245	184	66	5	191	130	316	255	441	380	566	505
	5+5	307	230	–	–	145	68	270	193	395	318	520	443
	7+5	369	278	–	–	97	6	222	131	347	256	472	381
MT26	2+2	196	124	251	179	438	366	626	554	813	741	1001	929
	3+3	294	185	190	81	377	268	565	456	752	643	940	831
	4+4	392	247	–	–	315	170	503	358	690	545	878	733
	5+5	490	309	–	–	253	72	441	260	628	447	816	635
	7+5	588	372	–	–	–	–	378	162	565	349	753	537
MT31	2+2	251	187	313	249	563	499	813	749	1063	999	1313	1249
	3+3	376	280	220	124	470	374	720	624	970	874	1220	1124
	4+4	502	374	–	–	376	248	626	498	876	748	1126	998
	5+5	627	467	–	–	283	123	533	373	783	623	1033	873
	7+5	753	560	–	–	–	–	440	247	690	497	940	747
MT36	2+2	412	306	494	388	894	788	1294	1188	1694	1588	2094	1988
	3+3	617	461	339	183	739	583	1139	983	1539	1383	1939	1783
	4+4	824	614	–	–	586	376	986	776	1396	1176	1786	1576
	5+5	1029	767	–	–	433	171	833	571	1233	971	1633	1371
	7+5	1236	921	–	–	–	–	679	364	1079	764	1479	1164
MT41	2+2	505	371	629	495	1129	995	1629	1495	2129	1995	2629	2495
	3+3	757	566	444	243	944	743	1444	1243	1944	1743	2444	2243
	4+4	1011	741	–	–	759	289	1259	989	1759	1489	2259	1989
	5+5	1263	929	–	–	572	237	1072	737	1572	1237	2072	1737
	7+5	1516	1113	–	–	–	–	887	484	1387	984	1887	1484

*Actuator drawings may be downloaded at www.max-airtechnology.com

SPRING RETURN MT51–MT76

		POS. 1 CLOSING TORQUE (SPRING)		POS. 2–OPENING TORQUE									
				40 PSIG		60 PSIG		80 PSIG		100 PSIG		120 PSIG	
#Springs		START	END	START	END	START	END	START	END	START	END	START	END
MT46	2+2	890	560	1002	672	1784	1454	2565	2235	3346	3016	4127	3797
	3+3	1334	840	722	228	1504	1010	2285	1791	3066	2572	3847	3353
	4+4	1779	1120	–	–	1224	565	2005	1346	2786	2127	3567	2908
	5+5	2224	1399	–	–	945	120	1726	901	2507	1682	3288	2463
	7+5	2669	1679	–	–	–	–	1446	456	2227	1237	3008	2018
MT51	2+2	1101	869	1381	1149	2506	2274	3631	3399	4756	4524	5881	5649
	3+3	1652	1304	946	598	2071	1723	3196	2848	4321	3973	5446	5098
	4+4	2203	1738	512	47	1637	1172	2762	2297	3887	3422	5012	4547
	5+5	2754	2173	–	–	1202	621	2327	1749	3452	2871	4577	3996
	7+5	3303	2607	–	–	768	72	1893	1197	3018	2322	4143	3447
MT56	2+2	1487	1055	1945	1513	3445	3013	4945	4513	6445	6013	7945	7513
	3+3	2231	1583	1417	769	2917	2269	4417	3769	5917	5269	7417	6769
	4+4	2974	2111	889	26	2389	1526	3889	3026	5389	4526	6889	6026
	5+5	3718	2638	–	–	1862	782	3362	2282	4862	3782	6362	5282
	7+5	4462	3166	–	–	1334	38	2834	1538	4334	3038	5834	4538
MT61	2+2	2146	1711	2839	2404	5114	4679	7389	6954	9664	9229	11939	11504
	3+3	3220	2566	1984	1330	4259	3605	6534	5880	8809	8155	11084	10430
	4+4	4293	3422	1128	257	3403	2532	5678	4807	7953	7082	10228	9657
	5+5	5366	4277	–	–	2548	1459	4823	3734	7098	6009	9373	8284
	7+5	6438	5133	–	–	1692	387	3967	2662	6242	4937	8517	7212
MT66	2+2	2810	2084	3916	3190	6916	6190	9916	9190	12916	12190	15916	15190
	3+3	4215	3126	2874	1785	5874	4785	8874	7785	11874	10785	14874	13785
	4+4	5619	4269	1831	381	4831	3381	7831	6381	10831	9381	13831	12381
	5+5	7024	5211	–	–	3789	1976	6789	4976	9789	7976	12789	10976
	7+5	8430	6252	–	–	–	–	5748	3570	8748	6570	11748	9570
MT71	1+1	2123	1534	10216	9627	16091	15502	21966	21377	27841	27252	33716	33127
	2+2	4247	3068	8682	7503	14557	13378	20432	19253	26307	25128	32182	31003
	3+3	6370	4602	7148	5380	13023	11255	18898	17130	27773	23005	30648	28880
	4+4	8493	6136	5614	3257	11489	9132	17364	15007	23239	20882	29114	26757
	5+5	10617	7670	–	–	9955	7008	15830	12883	21705	18758	27580	24633
	6+6	12740	9204	–	–	8421	4885	14296	10760	20171	16635	26046	22510
	7+7	14863	10737	–	–	–	–	12763	8637	18638	14512	24513	20387
	8+8	16987	12271	–	–	–	–	11229	6513	17104	12388	22979	18263
MT76	1+1	2843	1784	13966	12907	21841	20782	29716	28657	37591	36532	45466	44407
	2+2	5686	3569	12181	10064	20056	17939	27931	25814	35806	33689	43681	41564
	3+3	8530	5353	10397	7220	18272	15095	26147	22970	34022	30845	41897	38720
	4+4	11373	7137	8613	4377	16488	12252	24363	20127	32238	28002	40113	35877
	5+5	14216	8922	–	–	14703	9409	22578	17284	30453	25159	38328	33034
	6+6	17059	10706	–	–	12919	6566	20794	14441	28669	22316	36544	30191
	7+7	19902	12490	–	–	–	–	19010	11598	26885	19473	34760	27348
	8+8	22746	14275	–	–	–	–	17225	8754	25100	16629	32975	24504

* Actuator drawings may be downloaded at www.max-airtechnology.com

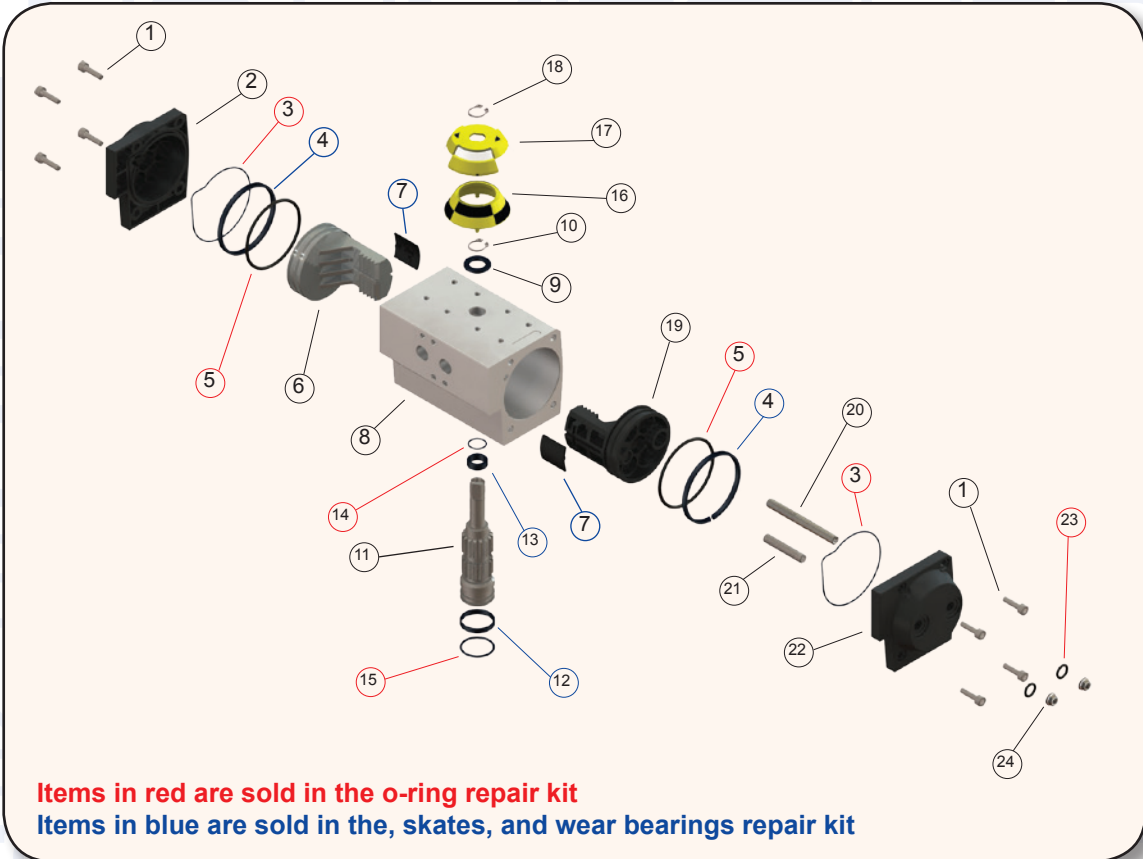

SEVERE COLD SERVICE
 For temperatures below -4°F down to -40°F, special low temperature seals and lubricant must be used.

STANDARD SERVICE
 Actuators come standard with BUNA-N seals, which are good for normal temperature ranges of -4°F to 176°F.

ELEVATED TEMP SERVICE
 For elevated temperatures up to 300°F, VITON® seals are available. Typical VITON® installations are good for 250°F continuous

HIGH TEMP SERVICE
 For extremely hot environments, special high temperature seals and lubricant must be used. Temperature ranges up to 500°F can be accommodated with our specially manufactured actuator units.

Item	Description	Materials	Item	Description	Materials
1	End Cap Bolts	AISI 304 Stainless Steel	13	Upper Pinion Bearing	Technopolymer
2	Left End Cap	Die Cast Aluminum Epoxy Coated	14	Upper Pinion O-Ring	BUNA-N
3	End Cap O-Ring	BUNA-N	15	Lower Pinion O-Ring	BUNA-N
4	Piston Wear Bearing	Technopolymer	16	Open/Closed Indicator	Technopolymer
5	Piston O-Ring	BUNA-N	17	Indicator Window	Technopolymer
6	Left Piston	Die Cast Aluminum Epoxy Coated	18	Indicator Snap Ring	AISI 304 Stainless Steel
7	Piston Skate	Technopolymer	19	Travel Stop Piston	Die Cast Aluminum Epoxy Coated
8	Actuator Body	Extruded Aluminum (6063 or 6005)	20	Closed Travel Stop	AISI 304 Stainless Steel
9	Upper Pinion Washer	Technopolymer	21	Open Travel Stop	AISI 304 Stainless Steel
10	Pinion Snap Ring	AISI 304 Stainless Steel	22	Travel Stop End Cap	Die Cast Aluminum Epoxy Coated
11	Pinion	Nickel Plated Carbon Steel	23	Travel Stop O-Rings	BUNA-N
12	Lower Pinion Bearing	Technopolymer	24	Travel Stop Nuts	AISI 304 Stainless Steel

Envelope dimensions shown, see individual cutsheets for dimensional details.

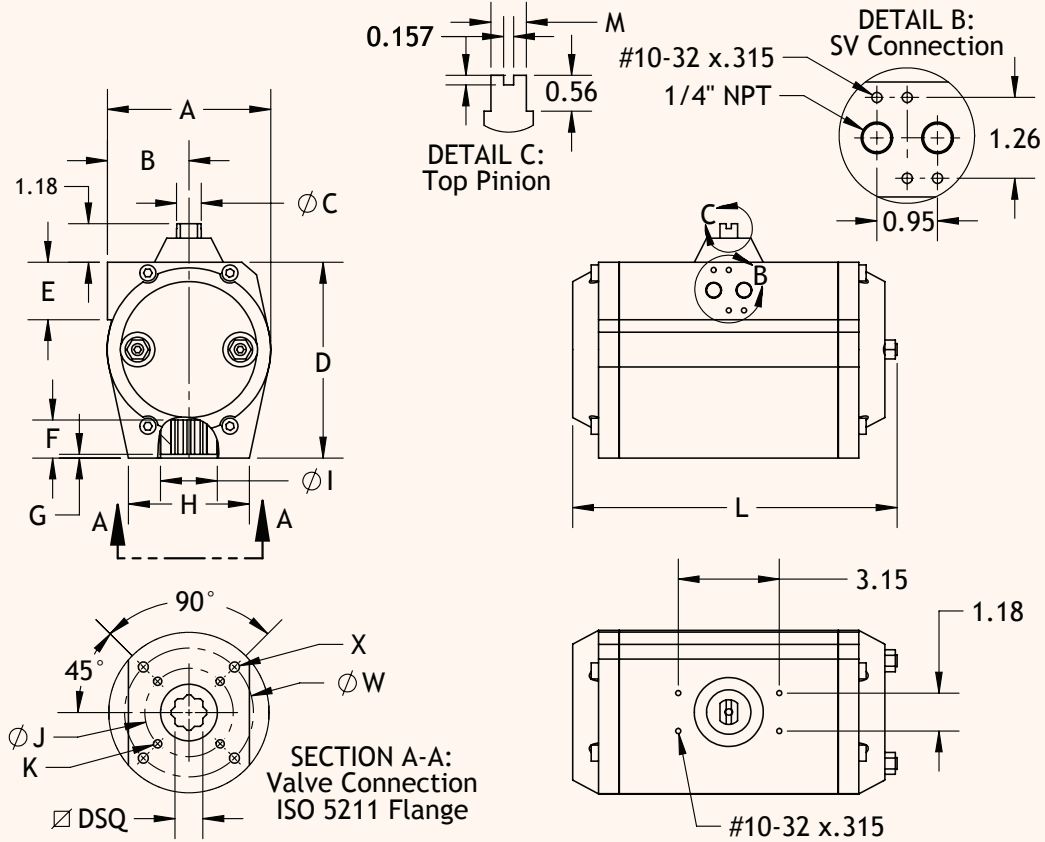

Please call for MT04 dimensions or visit www.max-airtechnology.com

Note: UT71 and MT71 are the same model, as are UT76 and MT76. Drawings can be downloaded at www.max-airtechnology.com

Type	A	B	C	D	E	F	G	H	I	L	M	J	K	W	X	DSQ	ISO 5211
MT12	2.64	1.57	0.47	2.80	1.77	0.49	0.06	1.85	0.87	4.69	0.394	1.42	#10-32x.394	1.969	1/4"-20x.394	0.4331	F03/F05
												1.65	#10-32x.394	—	—	—	F04
MT08	2.76	1.62	0.47	2.68	1.70	0.65	0.06	2.07	1.02	6.30	0.394	1.42	#10-32x.315	1.969	1/4"-20x.394	0.4331	F03/F05
												1.65	#10-32x.315	—	—	—	F04
MT16	3.19	1.85	0.47	3.19	1.75	0.75	0.08	2.44	1.30	6.50	0.394	1.97	1/4"-20x.394	2.756	5/16"-18x.512	0.5512	F05/F07
												1.65	#10-32x.394				F04/F07
MT17	3.19	1.85	0.47	3.19	1.75	0.75	0.08	2.44	1.30	7.76	0.394	1.97	1/4"-20x.394	2.756	5/16"-18x.512	0.5512	F05/F07
MT21	3.78	2.13	0.55	3.86	1.77	0.75	0.08	3.01	1.38	6.70	0.394	1.97	1/4"-20x.512	2.756	5/16"-18x.512	0.6693	F05/F07
MT26	3.78	2.13	0.55	3.86	1.77	0.75	0.08	3.01	1.38	9.41	0.394	1.97	1/4"-20x.512	2.756	5/16"-18x.512	0.6693	F05/F07
MT31	4.49	2.44	0.77	4.61	1.73	0.91	0.08	3.56	1.59	9.06	0.551	1.97	1/4"-20x.512	2.756	5/16"-18x.512	0.6693	F05/F07
MT36	5.16	2.60	0.77	6.06	1.77	1.18	0.12	3.76	1.59	9.69	0.551	2.76	5/16"-18x.512	4.016	3/8"-16x.709	0.8661	F07/F10
MT41	5.16	2.60	0.77	6.06	1.77	1.18	0.12	3.76	1.77	11.42	0.551	2.76	5/16"-18x.512	4.016	3/8"-16x.709	0.8661	F07/F10
MT46	5.71	2.87	1.10	6.63	1.77	1.18	0.12	3.88	2.22	13.81	0.787	2.76	5/16"-18x.512	4.016	3/8"-16x.709	0.8661	F07/F10
MT51	7.13	3.58	1.10	7.95	1.73	1.57	0.12	4.33	2.13	14.21	0.787	4.02	3/8"-16x.709	4.921	1/2"-13x.787	1.063	F10/F12
MT56	7.13	3.58	1.10	7.95	1.73	1.57	0.12	4.90	2.62	16.46	0.787	4.02	3/8"-16x.709	4.921	1/2"-13x.787	1.063	F10/F12
MT61	9.13	4.49	1.10	10.12	1.77	1.97	0.16	6.32	3.15	17.48	0.787	4.02	3/8"-16x.709	4.921	1/2"-13x.787	1.063	F10/F12
														5.512	5/8"-11x.984	1.4173	F10/F14
MT66	9.13	4.49	1.10	10.12	1.77	1.97	0.16	6.32	3.15	19.76	0.787	4.02	3/8"-16x.709	4.921	1/2"-13x.787	1.063	F10/F12
														5.512	5/8"-11x.984	1.4173	F10/F14
MT71	13.31	6.65	1.77	12.91	2.17	2.52	0.20	6.10	4.13	25.04	1.417	5.512	5/8"-11x1.260	—	—	1.811	F14
												6.496	3/4"-10x1.260	—	—	1.811	F16
MT76	13.31	6.65	1.77	12.91	2.17	2.52	0.20	6.10	5.51	28.90	1.417	6.496	3/4"-10x1.260	—	—	1.811	F16

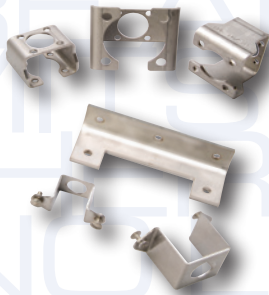

Max-Air TECHNOLOGY

The Best Way to Automate Your Process

Did you know that we provide the following services?

- 2D and 3D CAD Assembly Drawings
- Trained Technical Support Services
- On-site Commissioning Services
- Engineering System Design Services

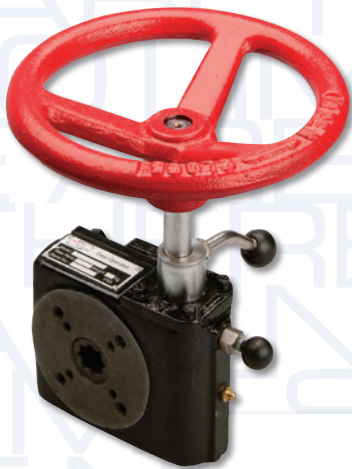
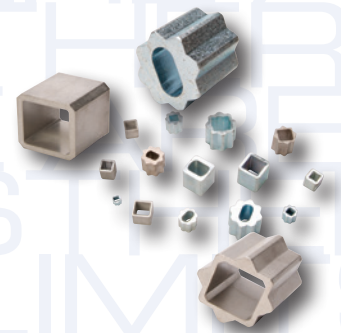

Your nearest Max-Air dealer can be found at:

